

DM860D



Stepper Motor Driver Specification

Overview

The DM860D is a new generation high-performance digital stepper driver based on DSP and PID control algorithm with microstep control technology. The motors driven by DM860D can run with much smaller noise and much less vibration than other drivers in the market. The DM860D possess the feature of lower noise, lower vibration, and lower heating. The DM860D's voltage is DC24V-80V. It is suitable for all the 2-phase hybrid stepper motor whose current is less than 6.0A. There are 16 kinds of microstep of DM860D. The maximum step number of DM860D is 51200 steps/rev (microstep is 1/256). Its current range 2.0A-6.0A, and its output current has 8 stalls. DM860D has automatic semi-flow, over-voltage, under voltage and over-current protection function.

Current selection

REF	Peak	SW1	SW2	SW3
2.00A	2.40A	ON	ON	ON
2.57A	3.08A	OFF	ON	ON
3.14A	3.77A	ON	OFF	ON
3.71A	4.45A	OFF	OFF	ON
4.28A	5.14A	ON	ON	OFF
4.86A	5.83A	OFF	ON	OFF
5.43A	6.52A	ON	OFF	OFF
6.00A	7.20A	OFF	OFF	OFF

Microstep selection

Pulse/REV	SW5	SW6	SW7	SW8
Default	ON	ON	ON	ON
800	OFF	ON	ON	ON
1600	ON	OFF	ON	ON
3200	OFF	OFF	ON	ON
6400	ON	ON	OFF	ON
12800	OFF	ON	OFF	ON
25600	ON	OFF	OFF	ON
51200	OFF	OFF	OFF	ON
1000	ON	ON	ON	OFF
2000	OFF	ON	ON	OFF
4000	ON	OFF	ON	OFF
5000	OFF	OFF	ON	OFF
8000	ON	ON	OFF	OFF
10000	OFF	ON	OFF	OFF
20000	ON	OFF	OFF	OFF
40000	OFF	OFF	OFF	OFF

Default: The pulse can be customized according to customers' requirements.

Common indicator

Phenomenon	Reason	Solution
The red indicator is on.	1. A short circuit of motor wires.	Inspect or change wires
	2. The external voltage is over or low than the driver's working voltage.	Adjust the voltage to a reasonable rang
	3. Unknown reason	Return the goods

Applications

It can be applied in a variety of small scale automation equipment and instruments, such as labeling machine, cutting machine, packing machine, drawing machine, engraving machine, CNC machine and so on. It always performs well when it is used in equipment which requires for low-vibration, low-noise, high-precision and high-velocity.

Driver functions descriptions

Driver function	Operating instructions
Output current setting	Users can set the driver output current by SW1-SW3 three switches. The setting of the specific output current, please refer to the instructions of the driver panel figure.
Microstep setting	Users can set the driver Microstep by the SW5-SW8 four switches. The setting of the specific Microstep subdivision, please refer to the instructions of the driver panel figure.
Automatic half current function	Users can set the driver half flow function by SW4. "OFF" indicates the quiescent current is set to half of the dynamic current, that is to say, 0.5 seconds after the cessation of the pulse, current reduce to about half automatically. "ON" indicates the quiescent current and the dynamic current are the same. User can set SW4 to "OFF", in order to reduce motor and driver heating and improve reliability.
Signal interfaces	PUL+ and PUL- are the positive and negative side of control pulse signal; DIR+ and DIR- are the positive and negative side of direction signal; ENA+ and ENA- are the positive and negative side of enable signal.
Motor interfaces	A+ and A- are connected to a phase winding of motor; B+ and B- are connected to another phase winding of motor. If you need to backward, one of the phase windings can be reversed.
Power interfaces	It uses DC power supply. Recommended operating voltage is 24VDC-80VDC, and power consumption should be greater than 350W.
Indicator lights	There are two indicator lights. Power indicator is green. When the driver power on, the green light will always be lit. Fault indicator is red, when there is over-voltage or over-current fault, the red light will always be lit; after the driver fault is cleared, if re-power the red light will be off.
Installation instructions	Driver dimensions:150×98×51mm, please refer to dimensions diagram. Please leave 10CM space for heat dissipation. During installation, it should be close to the metal cabinet for heat dissipation.

Signal interface details:

The internal interface circuits of the driver are isolated by the opt coupler signals, R in the figure is an external current limiting resistor. The connection is differential. And it has a good anti-jamming performance.

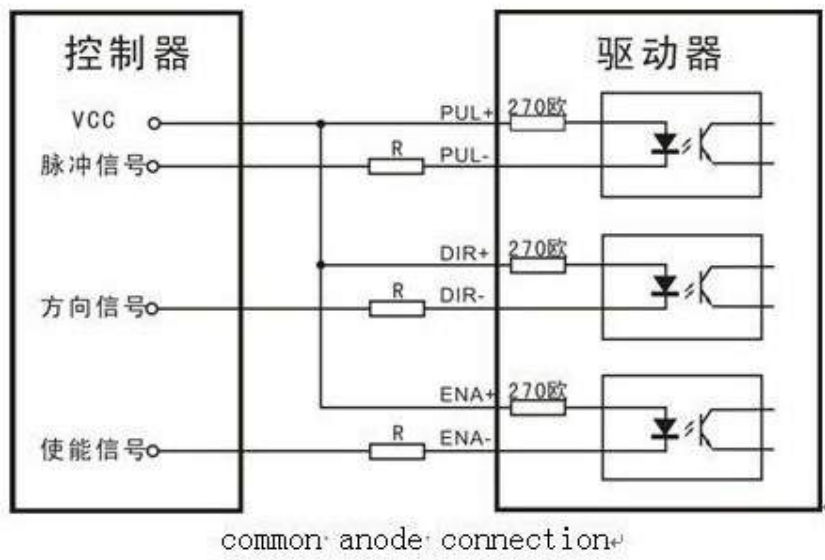
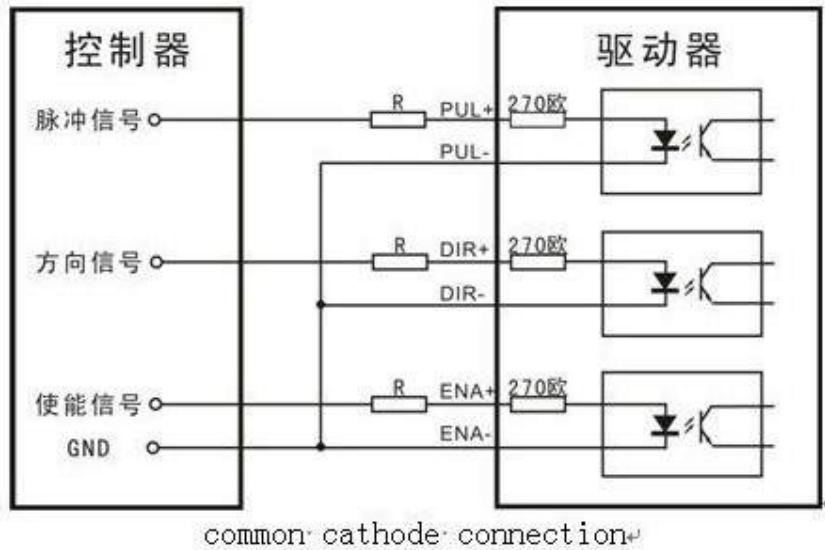

Control signal and external interface:

Signal amplitudes	External current limiting resistor R
5V	Without R
12V	680 Ω
24V	1.8K Ω

Outline and installation size (unit:mm)

